

# RW240/400/600 Motor Gearboxes

## Motor gearboxes

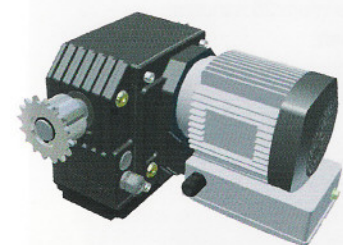
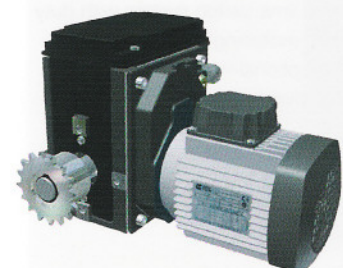
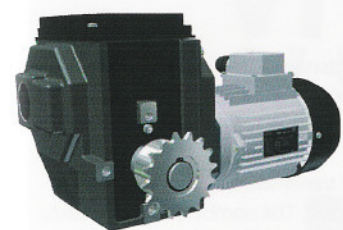

### RW400 Motor Gearboxes

The RW400 motor gearboxes are maintenance-free, compact power units for driving ventilation, screen, hoisting and flap ventilation systems in greenhouses and barns.

All RW400 motor gearboxes feature a self-braking worm gear transmission. This transmission ensures that the output shaft is braked when the drive unit is stopped. The combination of carefully matched pinion and worm reductions results in a very quiet mechanical transmission.

The RW400 motor gearboxes feature a patented integrated linear limit switch system with duty and safety switches having a great switching precision. The maximum switching range of the limit switch system equates to 86 revolutions of the drive shaft. Using the optional installation set with potentiometer, it is possible to precisely feed back the positions of a drive system to a (climate) computer.

The RW400 motor gearboxes are finished with a graphite gray powder coating and are supplied including fixing bolts and spring washers.

RW400 Motor Gearboxes:

- Drive torque up to 400Nm at 50 Hz and 60 Hz mains frequencies;
- Rotation speeds of 1 to 5 rpm at 50 Hz, 1.2 to 6 rpm at 60 Hz mains frequency;
- Suitable for intermittent duty, duty class s3-30%, duty cycle maximum 25 minutes;
- Fitted with 16-tooth 5/8"x3/8" zinc-plated sprocket for chain couplings;
- Manual drive enabled by means of hexagon in electric motor shaft;
- Electric motors are standard tropic-proof and conform to protection class IP55;
- Manufactured standard with 3-phase eurovoltage motors, for use on mains voltages of 400 V at 50 Hz and 480 V at 60 Hz (type A);
- Available with 3-phase wide voltage electric motors with CSA approval mark, for use on mains voltages from 208-415 V at 50 Hz and 60 Hz and 415-480 V at 60 Hz (type B);
- Available with 3-phase electric motors with CSA approval mark, for use on mains voltage of 575 V at 60 Hz (type C, available on request);
- Available with 1-phase electric motors for use on mains voltage of 230 V at 50 Hz and 60 Hz (type D, E);
- Available with 1-phase electric motors with CSA approval mark, for use on mains voltages from 115-120 V at 60 Hz (type F, G);
- Other specifications and colors available on request.

Art. no.	Description	Type	M (Nm) - 50Hz	n (/min) - 50Hz	M (Nm) - 60Hz	n (/min) - 60Hz	Phase	Art. no. electric motor	CSA	m (kg)
502210	RW403-37\400-450\3\86	A	400	3,0	400	3,6	3	763040		31,0
502220	RW405-55\400-450\3\86	A	400	5,0	400	6,0	3	763060		33,5
535660	RW403-37\208-480\3\C\86	B	400	3,0	400	3,06	3	704032	•	32,0
535690	RW405-55\208-480\3\C\86	B	400	5,0	400	6,0	3	704042	•	34,5
502240	RW403-37\220-240\1\OC\86	E	400	3,0	400	3,6	1	701031	•	33,0
502250	RW405-55\220-240\1\OC\86	E	400	5,0	400	6,0	1	701042	•	36,0
502239	RW403-37\110-115\1\60\OC\86	G	-	-	360	3,6	1	701232	•	33,0



52



55



61



63



195



103

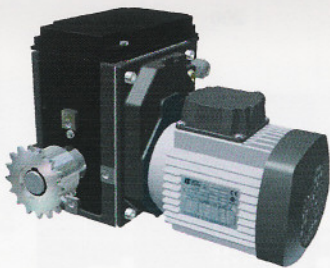

## RW400 Motor Gearboxes

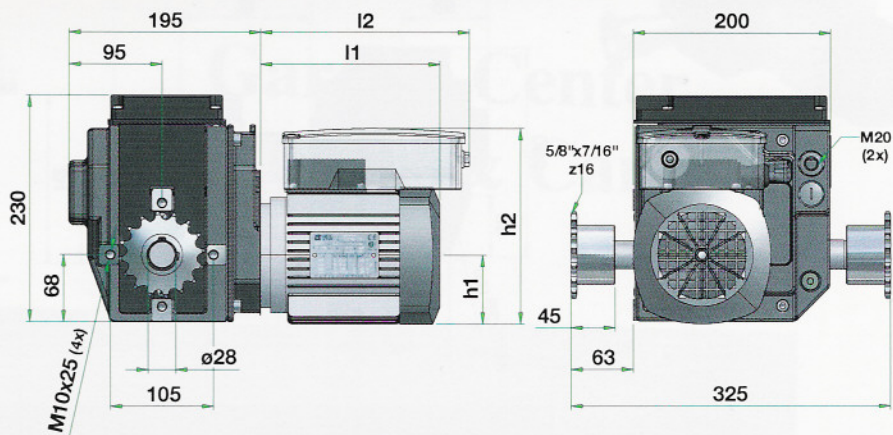

Art. no.	Description	m (kg)	l1 (mm)	l2 (mm)	h1 (mm)	h2 (mm)
502210	RW403-37\400-450\3\86	31,0	221		68,5	170
502220	RW405-55\400-450\3\86	33,5	237		77,5	190
535660	RW403-37\208-480\3\C\86	32,0	185		70	169
535690	RW405-55\208-480\3\C\86	34,5	215		79	193
502240	RW403-37\220-240\1\OC\86	33,0	196	212	70	200
502250	RW405-55\220-240\1\OC\C\86	36,0	215	215	79	225
502239	RW403-37\110-115\1\60\OC\C\86	33,0	193	207	70	210



## Straight mounting plates for RW240/400/600

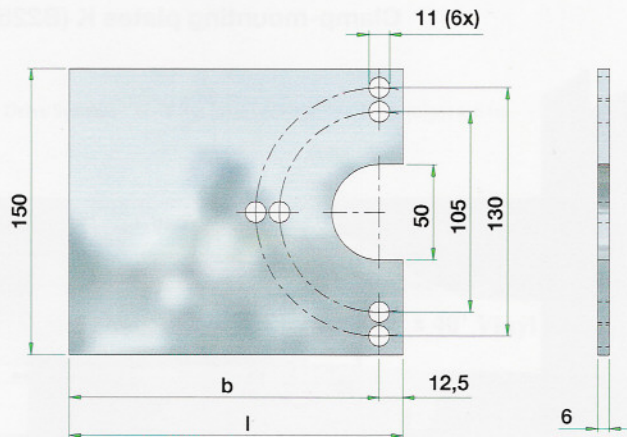

Art.nr.	Omschrijving	m (kg)	b (mm)	l (mm)
413921	MOUNTING PL 105-130\B163\BL	1,1	163	175,5
413922	MOUNTING PL 105-130\B163	1,15	163	175,5
413923	MOUNTING PL 105-130\B483.5	3,5	483,5	496
413924	MOUNTING PL 105-130\B503.5	3,6	503,5	516
413931	MOUNTING PL 105-130\B553.5	4,1	553,5	566
413933	MOUNTING PL 105-130\B503.5\BL	3,5	503,5	516
413934	MOUNTING PL 105-130\B483.5\BL	3,4	483,5	496
413935	MOUNTING PL 105-130\B527.5\BL	3,7	527,5	540

# RW Motor Gearboxes: Mounting

## Technical information

### Mounting positions for RW240/400/600 motor gearboxes

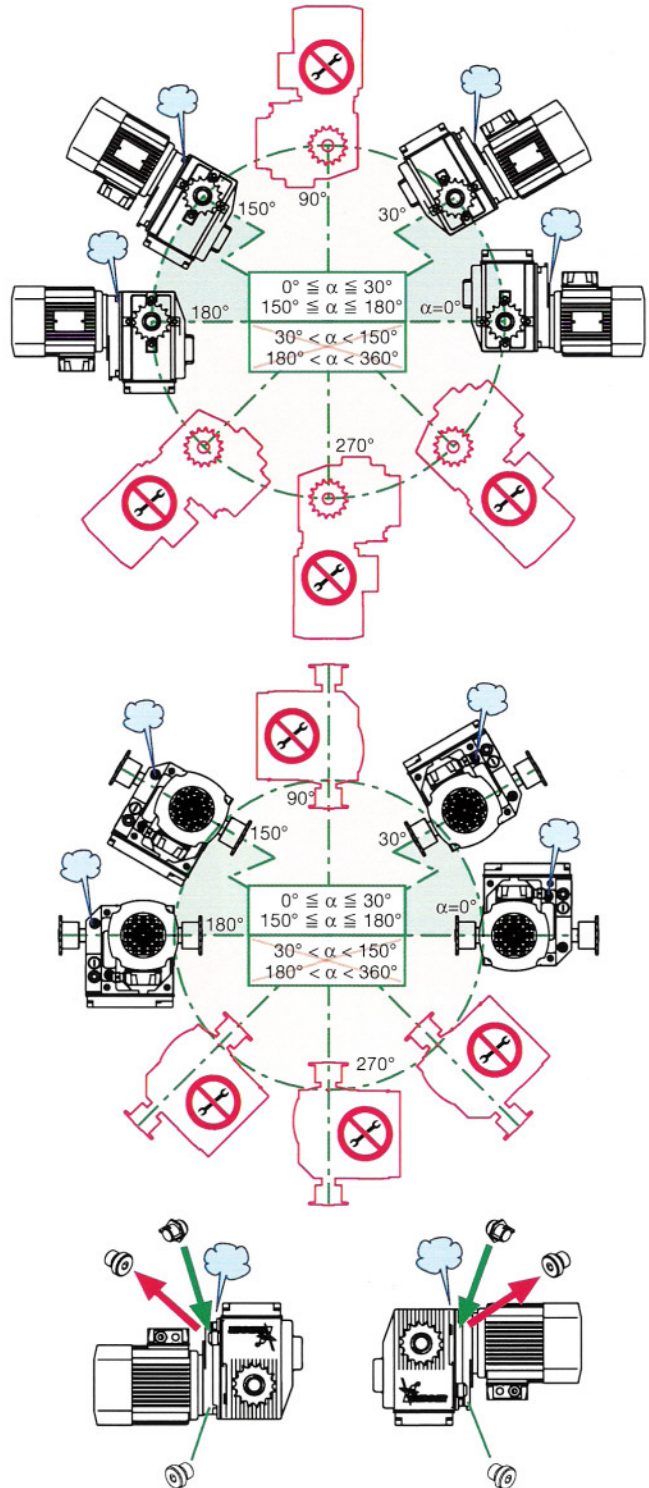
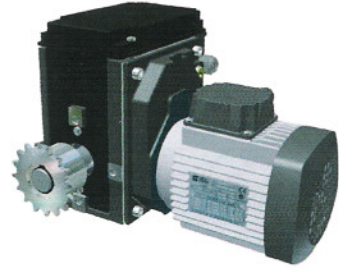

# RW Motor Gearboxes: RSU Limit switch system

Technical information

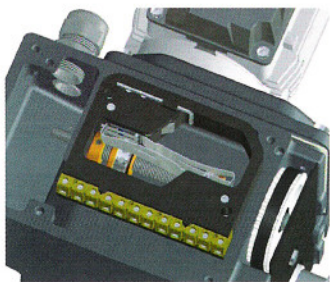

## RSU Limit switch system: Settings

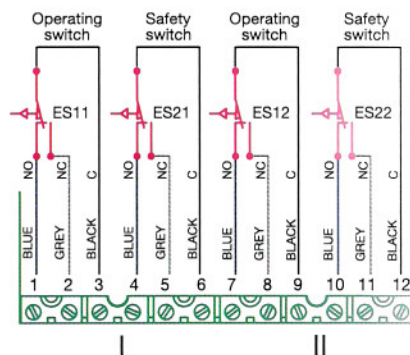
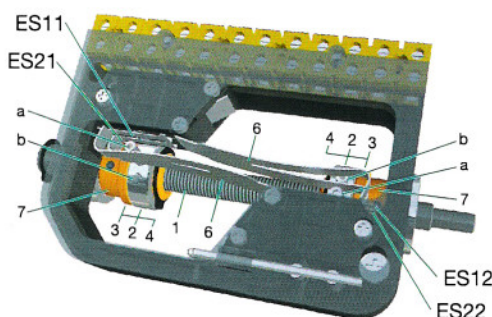
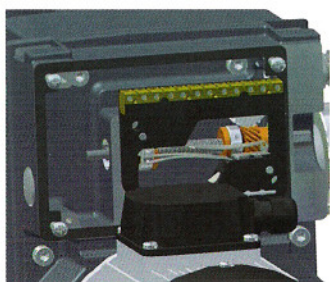

### RSU limit switch system installation

The steps required in order to correctly set the RSU limit switch system of an RW motor gearbox, are described below.

### Current and voltage range

The contacts in the switches of the Ridder RSU limit switch system, are capable of switching the following currents:

- 24 V-AC, currents from 45 mA to 130 mA;
- 230 V, currents up to 1 A.

### Ridder RSU limit switch system

The Ridder RSU limit switch system is a linear switch system, specifically designed for use in the RW motor gearboxes. The limit switch system is driven by the output shaft of the motor gearbox, via a secondary transmission. Depending on the type of motor gearbox, a number of revolutions of the output shaft can be set, between a starting and ending position. Depending on the type of motor gearbox, this will be 55, 86, 97 or 860 revolutions of the output shaft.

### How it works

This transmission drives the threaded shaft (1) of the Ridder RSU limit switch system, either with a toothed belt, or with a worm and gear combination. When running, the threaded switch followers (4) will move along the threaded shaft as it rotates. One setscrew (a) rests against the switch spring (6). When an end position is reached, the switch follower will strike the stop (7) and will then rotate with the threaded shaft. This deflects the switch spring, and a duty switch (S11 or S12) will be tripped. This causes a signal that activates the relay, stopping the motor gearbox. Should a relay or duty switch fail, then a safety switch (ES21 or ES22) will also be tripped by the switch spring. This causes a signal that activates a safety relay, stopping the controller and also thereby the motor gearbox. This prevents consequential damage to the driven system.

### Delivery

A Ridder motor gearbox with RSU limit switch system is delivered with switch followers (4) whose adjustment rings (3) still have to be fastened. This means that the drive can turn freely in both directions. This also avoids the possibility of causing damage to the limit switch system (when it has not yet been connected), should any (preset) limiting positions be exceeded during electrical or manual operation of the motor.

### Connection

When connecting the Ridder RSU limit switch system, please refer to the wiring diagrams provided for this purpose.

# RW Motor Gearboxes: RSU Limit switch system

## Technical information

### Setting

The "start position" and "end position" are set as follows:

1. By rotating the output shaft (manually or under power), bring the system to the "start position" or "end position" and determine which duty switch (ES11 or ES12) should be tripped. The switching sense of the RSU limit switch system can be reversed by swapping connections 1 and 7 in the connection block.
2. Turn the milled bush (2) on the appropriate side, "hand tight" up to the stop (7). The milled bush can easily be screwed by hand along the threaded shaft (1). The switch follower (4) also moves along the threaded shaft.
3. Now rotate the adjustment ring (3) over the milled nut just far enough to trip the duty switch.
4. Then fasten the adjustment ring with setscrews (a and b) firmly on the milled nut. The adjustment ring can no longer be rotated over the milled nut.
5. Repeat items 1 through 4 to adjust the limit switch system for the opposite rotation direction.

This completes the setting of the limit switch system.

### Caution

Take care: Once an RSU limit switch system has been set and the motor gearbox is operated manually, always make certain that the limiting positions set by the limit switch are never exceeded. This can seriously damage the limit switch system, such that the limit switch system no longer functions correctly!

## RW Motor Gearboxes: Maintenance

### Technical information

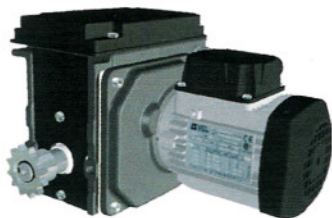

### Maintenance of RW motor gearboxes

#### Maintenance RW45 motor gear boxes

Regularly check your motor gearbox for operation performance and possible grease leakage. Inform your installer in case of grease leakage.

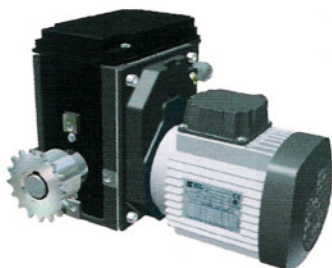

#### Maintenance RW240/400/600-RW1000/1200S/1400/1600S-RW200 motorgear boxes

Regularly check your motor gearbox for operation performance and possible grease leakage. Inform your installer in case of grease leakage.

**Beware:** When mounting place the vent plug in the highest position possible!

	RW45	RW240/400/600	RW1000/1400	RW200
Oil		Ridder EPX	Ridder EPX	Ridder EPX
Grease	Ridder SPH			
Contents	0,9 kg	1,15 l	1,5 l	1,1 l